

CUSTOM WATER AND WASTE TANK DESIGN GUIDE

This sheet has been designed to help you decide which type of fittings and accessories you require on your custom built tank. There are five points you need to address.

- **Hose Tail Fittings**
- **Avoiding Internal Baffles**
- **Inspection Hatches**
- **Senders**
- **The Tank Drawing**

These sections are described in detail in the following pages. Check off each heading as you cover them. You may decide that a sender is not necessary as you will be able to see the contents through the tank wall, so just ignore that section.

Hose Tail Fittings

First decide where the fittings need to go. Once you have established the position, the size has to be decided. Once the size has been decided, you need to check on the chart for the overall height or length of the fitting. This height or length can then be checked against the tank design to see if there are any problems with clearance. For example, you may have a clearance above your tank design of 75mm and want to fit an 1 1/2" elbow inlet. This would not be possible as an 1 1/2" elbow actually stands up 95mm and would foul whatever is above the tank. The tank height would then have to be reduced by 20mm to allow for the fitting.

Please note that all fittings whether straight or elbows are screwed onto a BSP threaded male adaptor, which is permanently welded to the tank. All adaptors will stand 24mm off the tank face when the fitting is removed. Dimension B includes the adaptor.

Each fitting needs to be checked against the tank design and the boat structure to avoid any problems later when the tank is fitted. Time spent now checking the size and position of each fitting will pay off, as it is normally not possible to modify the tank.

Please see the back of this sheet to see a typical custom tank drawing and how the fittings should be marked up. You may wish to provide the information in a different format, which is not a problem as long as all the information is clear.

If a dip pipe is required, for example an outlet on the top of the tank, then please add the suffix DP to the fitting type. e.g. an 1 1/2" elbow outlet on the top face will be shown as E5DP.

All elbows are multi directional; hence the direction they need to point does not need to be shown. Once the tank is installed they can be swivelled in the right direction and the locknut tightened.



Photo is unavailable

ELBOWS

STRAIGHTS

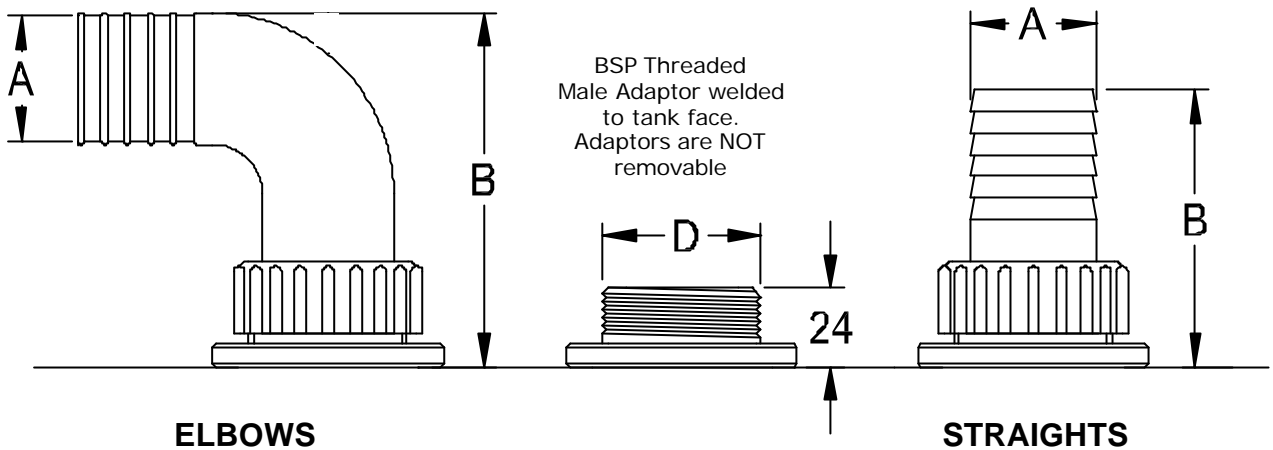

Fitting Type	Hose Bore (A)	Height (B)	BSP (D)	Fitting Type	Hose Bore (A)	Height (B)
E1	13mm	60mm	3/4"	S1	13mm	64mm
E2	16mm	62mm	3/4"	S2	16mm	64mm
E3	20mm	70mm	3/4"	S3	20mm	68mm
E4	25mm	74mm	1"	S4	25mm	74mm
E5	38mm	108mm	1 1/2"	S5	38mm	92mm
E6	50mm	110mm	2"	S6	50mm	100mm

Avoiding Baffles

When designing your tank, it is important that the fittings avoid any baffles that we put in. A custom tank can have fittings in almost any position, the only restriction being the baffles. Nearly all custom built tanks will have baffles unless the tank is very small, then it will have none.

The baffle spacing is based upon the length of the tank. All Tek-Tanks custom built tanks have equal baffle spacing where possible. The spacing is normally between 250 and 350mm depending on how the length divides up. For example a tank 1200mm long will have 3 baffles with four compartments 300mm wide. A tank 675mm long will have 1 baffle with two compartments 337.5mm wide. If in doubt about the number of baffles a tank will need, then please phone for advice.

The same will apply to inspection hatches. An inspection hatch cannot straddle two compartments; it has to be in one or the other. Please see below for dimensions of the 3 different hatch types.

Inspection Hatches

At Tek-Tanks we use 3 different types of inspection hatches, all of which are suitable for water and waste holding tanks.

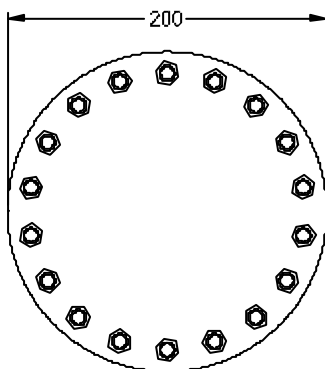

200 Standard Nuts & Bolts
25mm High

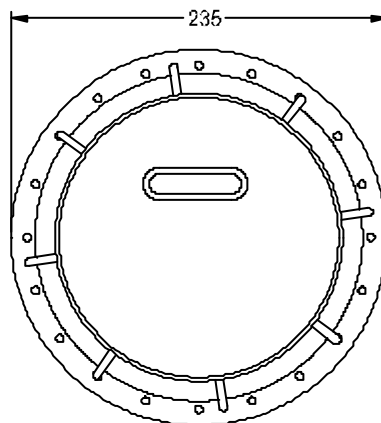

Henderson TCL4
32mm High

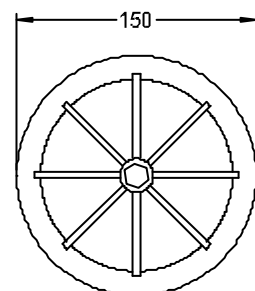

Wema
25mm High

The 200 Standard nuts and bolts hatch is manufactured from the same material as the tanks (HDPE) and comes with 18 x M8 studs fixed from inside the tank. The hatch seats on a 3mm thick nitrile gasket and is fixed with 18 x M8 nuts and washers. Fitting and removal requires a spanner.

The Henderson TCL4 hatch is a larger unit and stands slightly higher. This hatch seats on a 3mm nitrile gasket and is fastened with 20 x M5 button head screws. This is more suitable for quick access as it only requires a few turns and does not need any tools.

The Wema hatch is the smallest and is ideally suited for the smaller tank. It is fixed with a single central bolt that screws into an inner flange and seals with a large O ring between the top flange and the tank. Fitting and removal requires a spanner.

Senders

At Tek-Tanks we use only 1 type of sender on the water tanks and 2 types on the waste holding tanks. The drawings for each of these are shown below. The water tank senders are manufactured by Wema and have a prefix W2. The length of the sender is not important as far as your tank design goes, but the height when fitted may well be. The same applies to the waste holding tank sensors the Tankwatch 1 and the Tankwatch 4.

For more details on these units please visit the website or phone for more details. The W2 series water tank senders screw into a welded 1 ¼" BSP boss. The boss is not removable but the sender is.

The Tankwatch 1 is screwed to the top of the tank with 4 self-tapping screws and is easily removed if required. The Tankwatch 4 screws into a flange, which is bolted to the tank and sealed with a gasket. The flange can be removed by unbolting the 5 bolts.

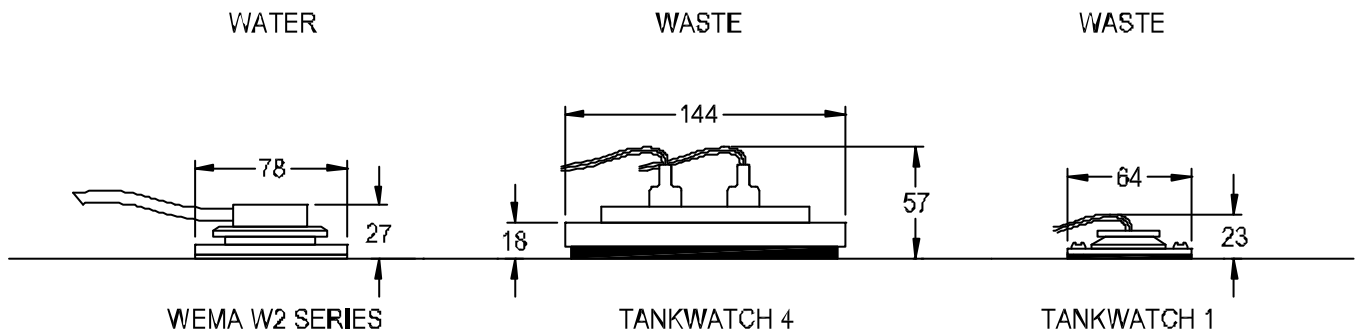

Tank Drawing

It is important to provide us with as much information as possible when designing your tank. We will need the overall dimensions and a clear indication of where the fittings are going to go. If the position of the fittings is critical then they will have to be dimensioned from the edges of the tank. If they are not critical then we will put them as near as possible to the position indicated.

When positioning the hatch or hatches, just remember to bear in mind where the baffles will be, again give us a call if you are uncertain.

On a very complicated tank with many angles, please indicate any square corners if any. This will help us greatly when we come to draw up the tank on our computer aided design system.

Another method of supplying us with the information we need, is to supply us with a template or mock up in either plywood or cardboard. By doing this you can satisfy yourself that the tank can be easily installed and that you can actually get it in or out of the boat or vehicle. The template can then be marked up with all the relevant fittings and hatches and either sent to us flat packed or you can bring it along to the factory to discuss in detail.

For quotation purposes a drawing will suffice.

The following drawing is how we would ideally like the information presented but we do realise that not everyone is a draughtsman and has access to drawing programs. A hand drawn sketch is fine as long as all the information is there.

Tank design using computer

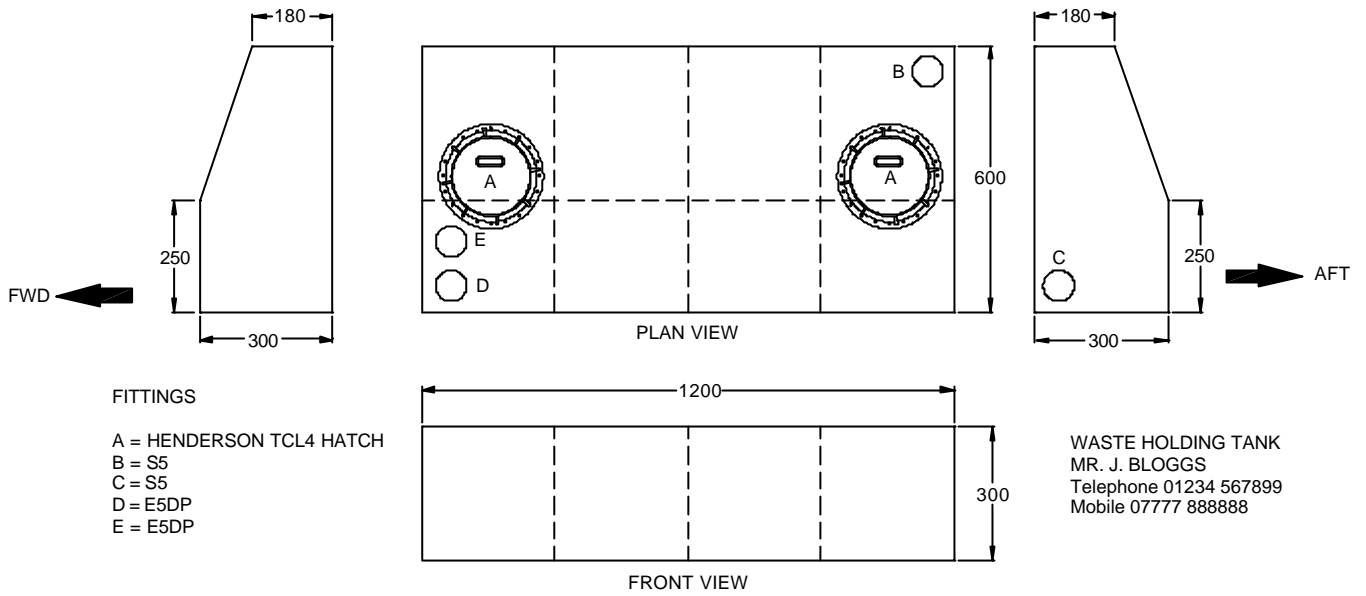

Hand drawn tank design

