

TEK-TANKS USE ONLY

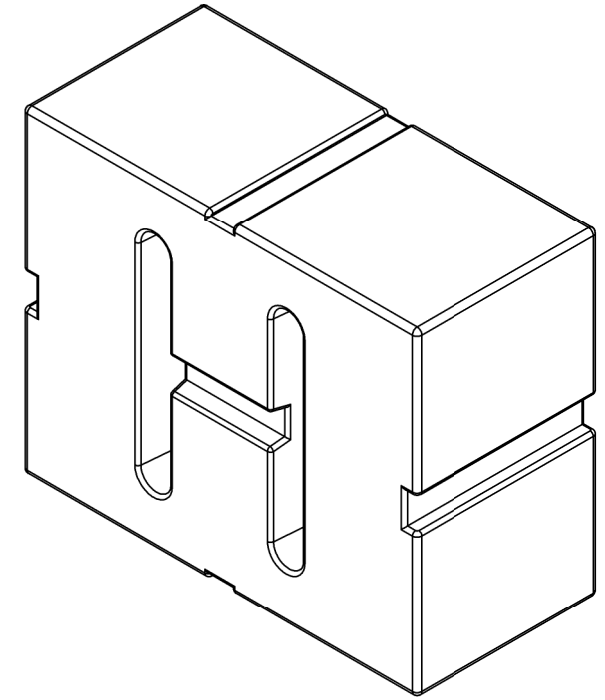
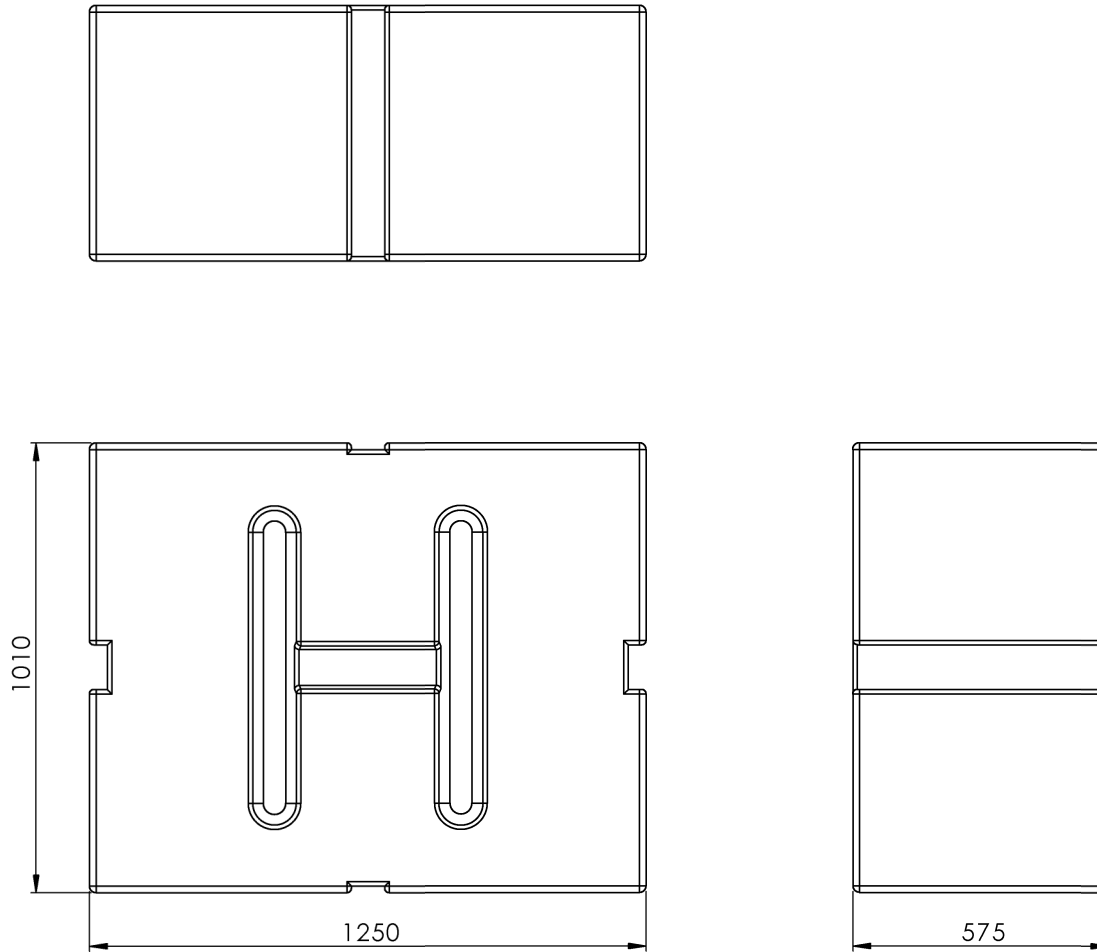

APPLICATION	✓	FITTING SPECIFICATION			
		TYPE	SIZE	DESCRIPTION	QTY
DIESEL		EXAMPLE	38mm	90° Elbow Hosetail	1
OIL	#	FILLER/INLET			
FRESH WATER	A	VENT			
GREY WATER	B	FEED/OUTLET			
WASTE	C	RETURN/INLET			
	D	DRAIN			
	E	SENDER			
	F	HATCH			
	G				

TEK TANKS
 Tek-Tanks LTD, The Old Stables, West End Farm,
 Upper Froyle, Alton, Hampshire, GU34 4JR
 tel: 01420 520 830 fax: 01420 520 840
 email: enquiries@tek-tanks.com web: www.tek-tanks.com

TITLE:
650 ltr Series A Baffled Tank

DWG NO.
650LITREBLANK

REVISION

DATE: 25 August 2016 DRAWN BY: RichardAB

Dimensions in 'mm' - Do Not Scale

A3