

# J-Series Vacuum Generator Installation Instructions



**Dometic Sanitation Corporation**  
 13128 State Rt. 226, P.O. Box 38  
 Big Prairie, OH 44611-0038 USA  
 330-496-3211  
 1-800-321-9886 • Fax: 330-496-3097

® Registered; ™ Trademark of Dometic Corporation  
 © Dometic Corporation

## Dimensional Specifications

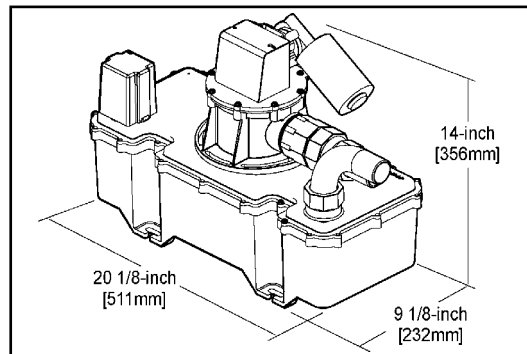

## Electrical Specifications

Model	Volts (DC)	Power Draw	GPM (LPM)	Fuse/Breaker	Wire Size	Lbs. (Kg)
VG412	12	6 amp (avg.)	5.1 (19.3)	10 amp	follow ABYC recommendations	15.1 (6.9)
VG424	24	3 amp (avg.)	5.1 (19.3)	5 amp		15.1 (6.9)

## Before installing the vacuum generator, you must consider the following:

1. Vacuum generator must be mounted horizontally only.
2. The vacuum generator can be mounted up to 50 feet (15.2 m) from the VacuFlush toilet, and 20 feet (6.1 m) from the holding tank.
3. The vacuum generator inlet must not be mounted more than 6 feet (1.8 m) higher than the toilet discharge outlet.
4. The maximum head pressure on the discharge of the vacuum generator must not exceed 6 feet.

**Note:** Two-toilet systems require a vacuum generator for each toilet (except for some electrically operated toilet installations).

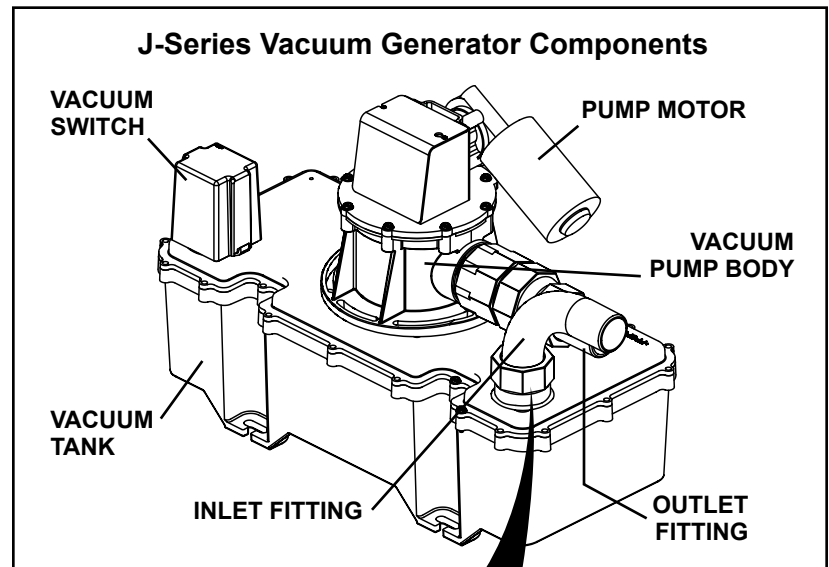

**ATTENTION:** Tighten inlet fitting spin-nut 1/2-turn past hand tight with wrench.

## INSTALLING THE VACUUM GENERATOR

1. Make sure the vacuum generator is properly located before proceeding. Place the vacuum generator on the surface to be mounted. Position as needed. Using a center punch, mark the four slotted holes in the pump feet. Remove vacuum generator.
2. Using a 3/16-inch drill bit, drill the four mounting holes. Use #14 wood screws and washers to secure vacuum generator.
3. Position pump body to accommodate plumbing layout, if necessary, by loosening four fasteners that hold pump onto vacuum tank, rotating pump body to desired position, and retightening fasteners.
4. Spin-nut connections on inlet and outlet fittings allow easy installation and positioning of hoses. After positioning inlet fitting in proper direction to accept inlet hose from toilet, **tighten spin-nut 1/2-turn past hand tight with wrench.** Use two hose clamps for each hose connection.

**Reminder:** For proper operation, the vacuum generator must be mounted horizontally. Make sure to connect the discharge hose from the VacuFlush toilet to the inlet fitting of the vacuum generator.

**Reminder:** The best system will position the vacuum generator at the same level or lower than the VacuFlush toilet.

## WIRING

Wire the vacuum generator as shown in the wiring diagram. Use multistranded copper wire. Protect the wiring by installing grommets or other protective device at holes and sharp edges. Proper fuse or circuit breaker size is extremely important for pump and wire protection. Over-fusing this pump will result in warranty invalidation.

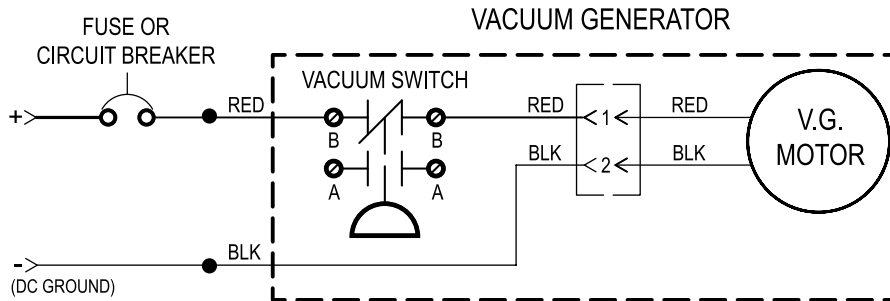

All voltages of vacuum generators are wired in the same manner. Route wire from positive source (+) through correct size circuit breaker or fuse to red wire at vacuum generator. Route wire from DC ground (-) to black wire at vacuum generator. (If desired, the pre-wired connector on the vacuum generator can be cut off if necessary to complete wiring operation.)

**Note:** Do not over-fuse the vacuum generator. To protect the motor, use only the fuse capacities shown on chart (see reverse side). Over-fusing will void the product warranty.

## VACUUM TESTING

1. Prime pump with water before performing vacuum test.
2. POSITIVE PRESSURE TESTING IS NOT RECOMMENDED for J-series vacuum generators. The unit is designed to seal with negative pressure (vacuum), and not hold positive pressure.

---

**Dometic Corporation manufactures a complete line of sanitation products and systems. Write or call the factory to receive free literature on the following products:**

- VacuFlush® Toilet Systems
- SaniPottie® Portable Toilets
- SeaLand® Liquid and Dry Deodorant Products
- SeaLand® Environment-Friendly Holding Tank Deodorant
- SeaLand® brand Toilet Tissue
- SeaLand® Toilet Bowl Cleaner
- SaniGard™ Holding Tank Vent Filter
- OdorSafe® Plus Sanitation Hose and Fittings
- TankWatch® Holding Tank Level Monitors