

SN 31 COMFORT PUMPED ELECTRIC MACERATOR TOILET DATA SHEET



Quiet and effective.
Discharge is through a conventional 1"- 11/2"
Hose. Will discharge to a higher head than
most other toilets.

No other macerator pump achieves the
Sanimar Comfort performance while operating
in virtual silence. The result is a comfortable
on-board facility at a very reasonable cost.

FEATURES:

- Operated by a two-position switch:
"ADD WATER" - bowl flush command
"PUMP OUT" - macerate and empty command
- Minimal routine maintenance
- Easy to clean
- 2 year guarantee

PART NUMBERS:

12 V - 03825
24 V - 03826

TECHNICAL SPECIFICATIONS:

Water consumption:	1.2 litre - 2.2 litres
Water pressure:	20-45 psi
Water connection:	3/4" BSP
Waste outlet:	1" or 1 1/2" 25 or 38 mm
Electric consumption:	12 Volt 21 Amps 24 Volt 11 Amps
Start-up surge:	12 Volt 133 Amps 24 Volt 69 Amps
Pumping height:	3 meters 260 Watts
Horizontal pumping distance:	30 meters 260 Watts

DIMENSIONS:

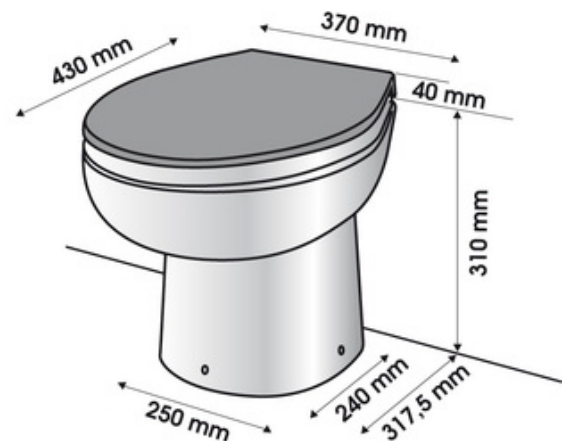

Weight: 18 kgs

Tek-Tanks Ltd

The Old Stables, West End Farm, Colthouse Lane, Upper Froyle, Alton, Hampshire, GU34 4JR
Telephone: +44 (0) 1420 525478, Fax: +44 (0)1420 520840
Website: www.tek-tanks.com E-mail: sales@tek-tanks.com